

TANK DESIGNED AS PER AS/NZS 1546.1 STANDARDS

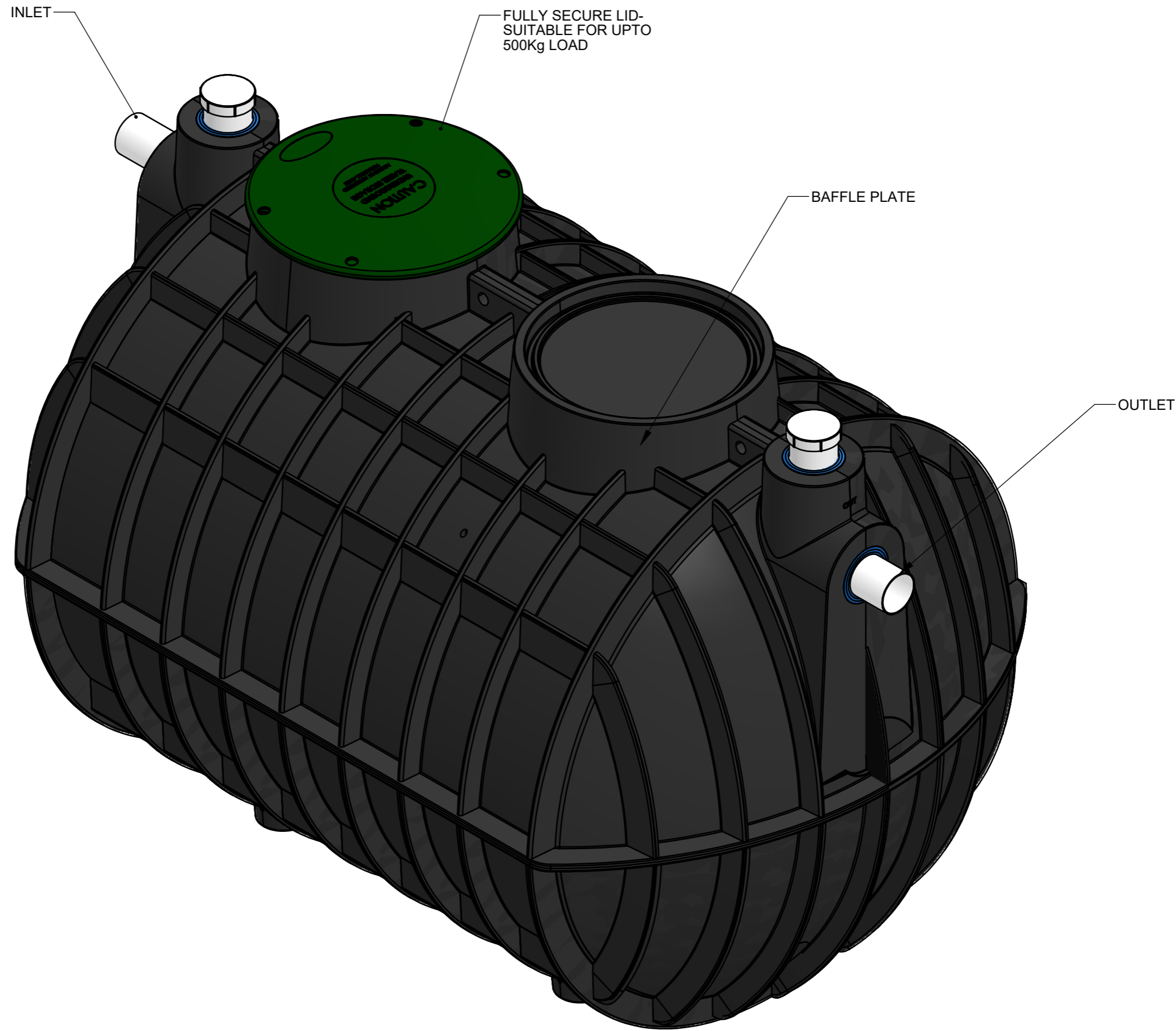

NOTE: ALL TOLERANCES UNLESS OTHERWISE STATED $\pm 10\text{mm} / \pm 1^\circ$
DO NOT SCALE, USE DIMENSIONS. ALL DIMENSIONS ARE IN mm

This drawing is the property of Polymaster Group Pty. Ltd. It cannot be copied in part or in full without the written permission of Polymaster Group Pty. Ltd.



161 KARINIE STREET
SWAN HILL. VIC.
3585
Ph: (03) 5033 9000
Fx: (03) 5033 0224

DESCRIPTION	Septic Tank 3100L	A3 SHEET SIZE	SCALE: NTS
PRODUCT CODE	ST3100		
MATERIAL	LLDPE 7032		
COLOUR	BLACK		
© POLYMASTER GROUP		DRAWN	AC
		21/06/2018	1/3 Rev: C

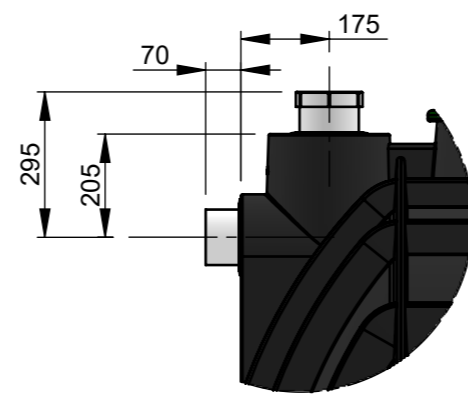
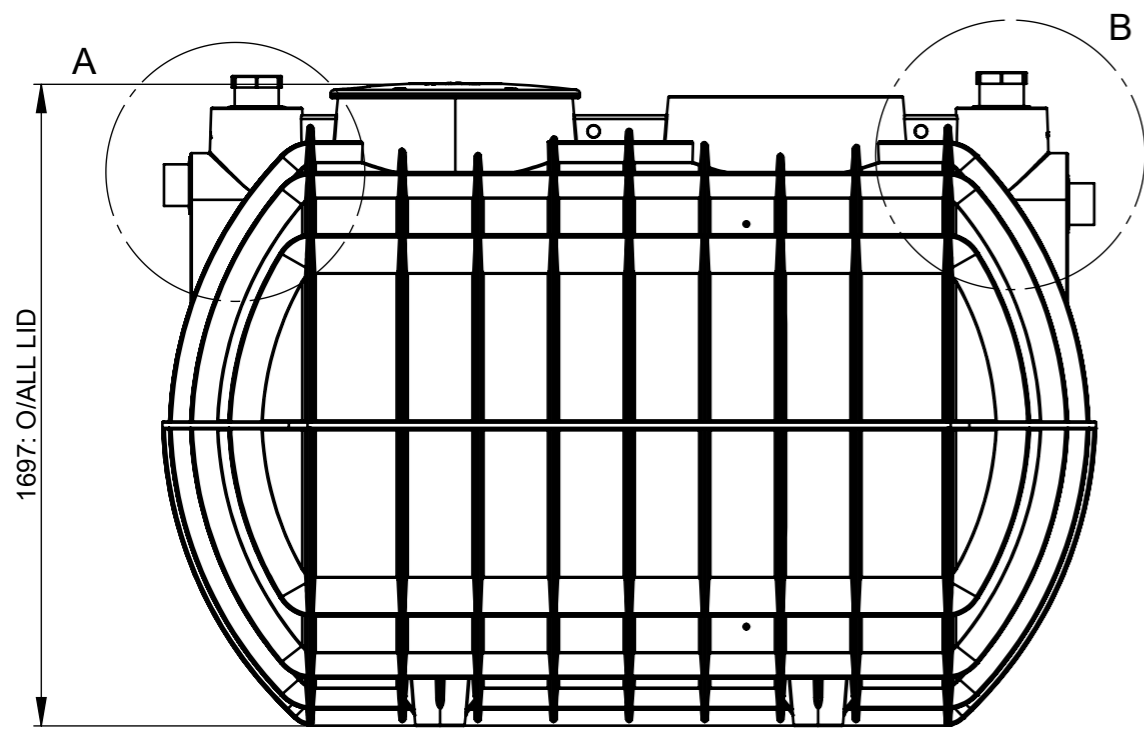

DETAIL A
(INLET)
SCALE 1 : 15

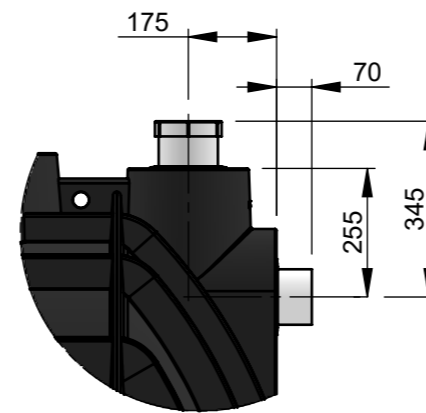
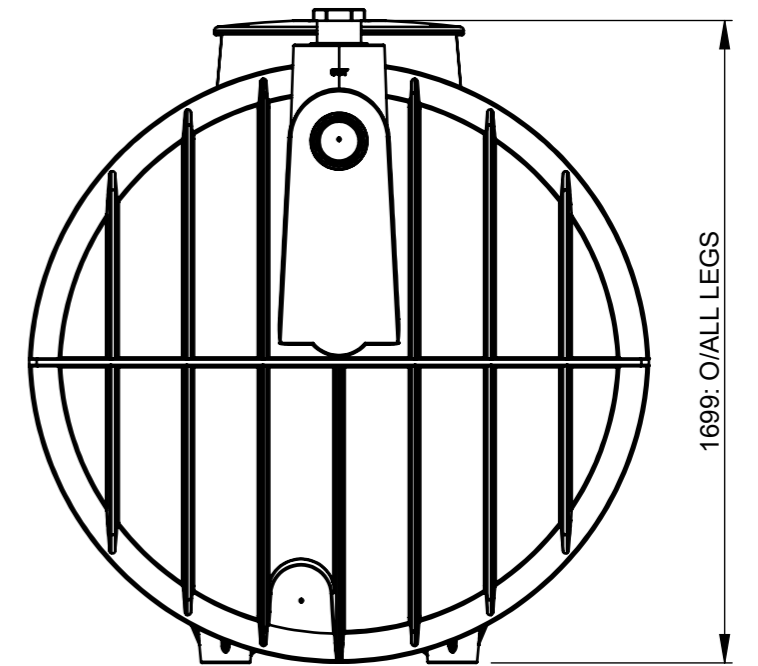

DETAIL B
(OUTLET)
SCALE 1 : 15

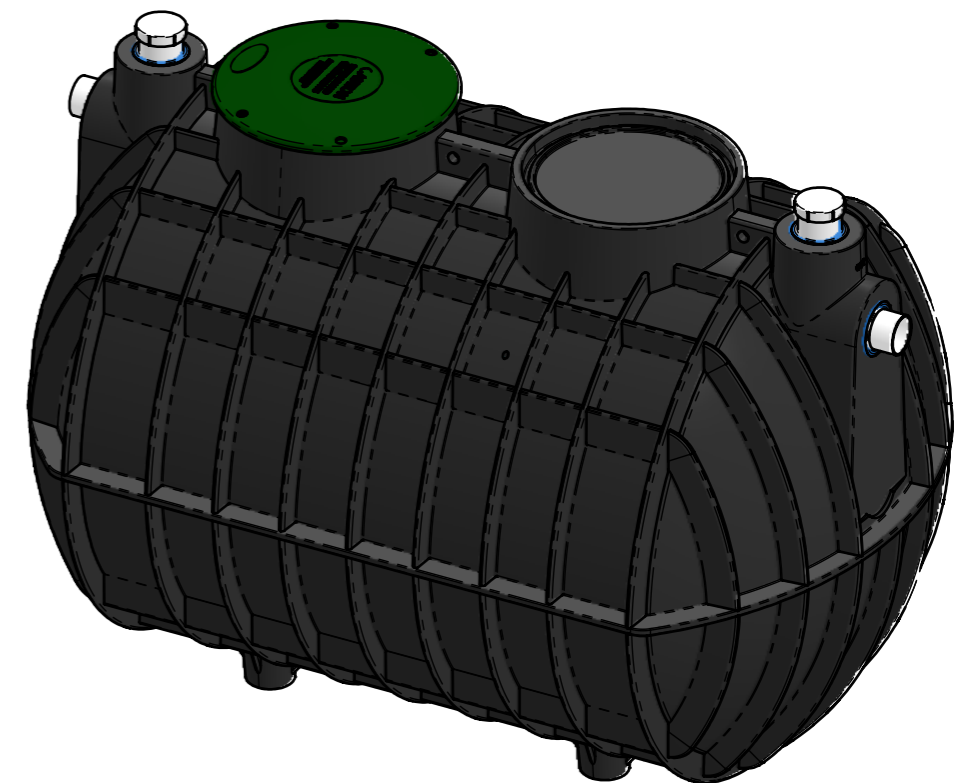
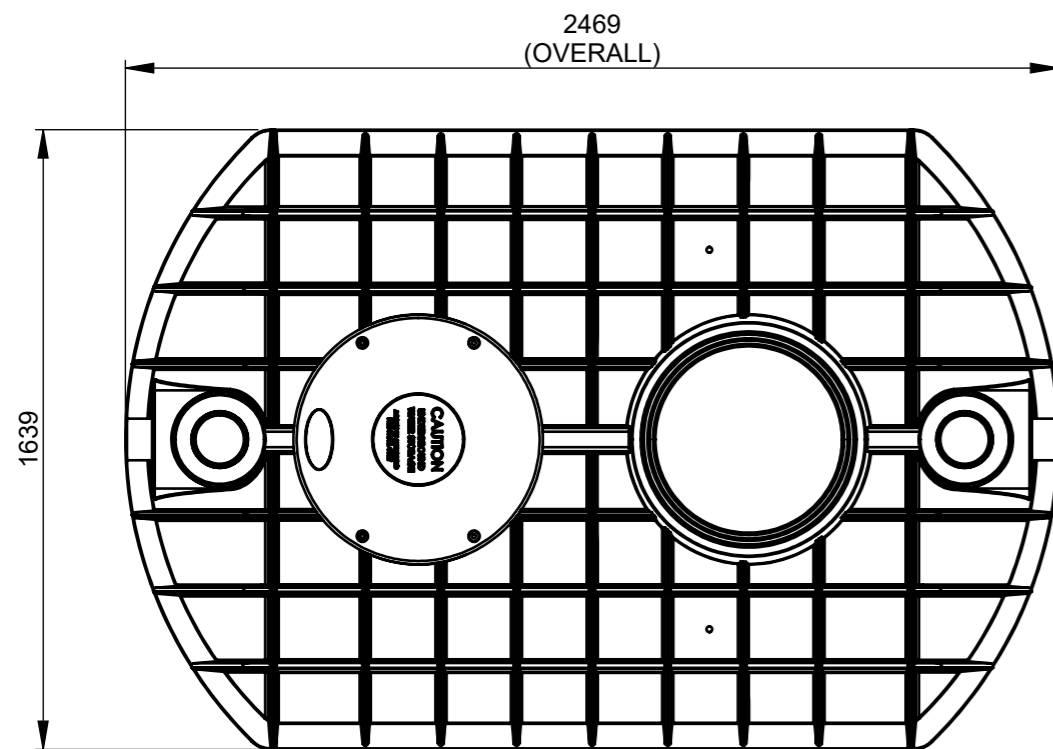

NOTE: ALL TOLERANCES UNLESS OTHERWISE STATED $\pm 10\text{mm} / \pm 1^\circ$
DO NOT SCALE, USE DIMENSIONS. ALL DIMENSIONS ARE IN mm

This drawing is the property of Polymaster Group Pty. Ltd. It cannot be copied in part or in full without the written permission of Polymaster Group Pty. Ltd.



161 KARINIE STREET
SWAN HILL. VIC.
3585
Ph: (03) 5033 9000
Fx: (03) 5033 0224

DESCRIPTION	Septic Tank 3100L	A3 SHEET SIZE	SCALE: NTS
PRODUCT CODE	ST3100		
MATERIAL	LLDPE 7032		
COLOUR	BLACK		
© POLYMASTER GROUP		DRAWN	AC 21/06/2018 2/3 Rev: C

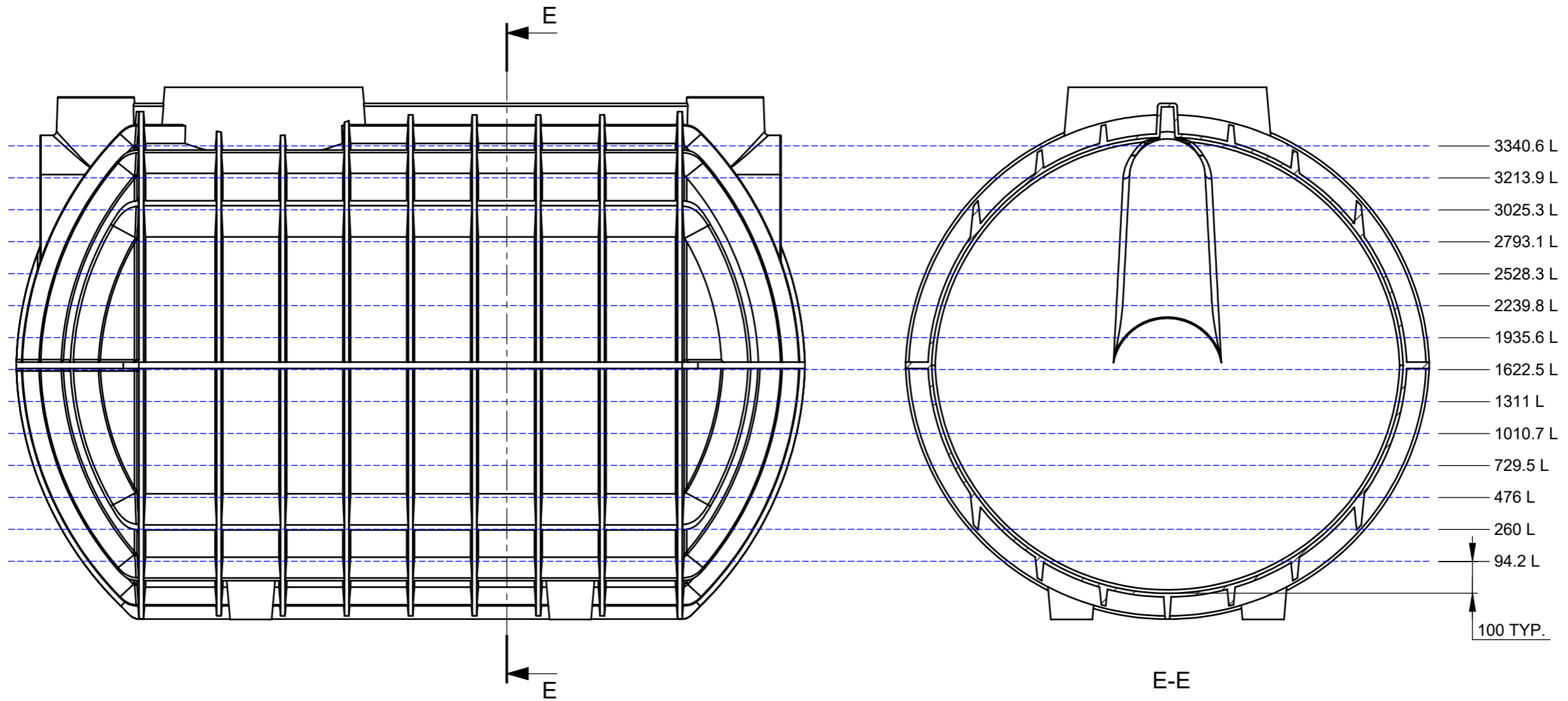

TANK'S STORAGE

NOTES:

- THE VOLUME IS GIVEN IN LITERS EVERY 100mm UPWARDS FROM THE INTERNAL BOTTOM FACE OF THE TANK.

NOTE: ALL TOLERANCES UNLESS OTHERWISE STATED $\pm 10\text{mm} / \pm 1^\circ$
DO NOT SCALE, USE DIMENSIONS. ALL DIMENSIONS ARE IN mm

This drawing is the property of Polymaster Group Pty. Ltd. It cannot be copied in part or in full without the written permission of Polymaster Group Pty. Ltd.



161 KARINIE STREET
SWAN HILL. VIC.
3585
Ph: (03) 5033 9000
Fx: (03) 5033 0224

DESCRIPTION	Septic Tank 3100L	A3 SHEET SIZE	SCALE: NTS
PRODUCT CODE	ST3100		
MATERIAL	LLDPE 7032		
COLOUR	BLACK		
© POLYMASTER GROUP		DRAWN	AC 21/06/2018 3/3 Rev: C