

The Polymaster logo features the brand name in a white, sans-serif font. A red, hand-drawn style circle is drawn around the 'o' in 'master', with the top of the circle extending over the 'P' and the bottom extending under the 's'.

Polymaster



Installation & maintenance guide

Underground Rainwater Tanks

Thank you for purchasing a quality Polymaster Tank!

About Polymaster

A TRUSTED PARTNER

After a quarter of a century, Polymaster now stands as the industry standard in liquid storage. Why? Because we deliver more than a product. We deliver a promise. We are relied upon to store, secure and safeguard on behalf of our customers.

SOLUTIONS DELIVERED AT EVERY SCALE.

Whether it's a humble backyard water tank, complex chemical storage or vital firefighting equipment, we take on the responsibility our customers put in us because we know we have the unrivalled experience to deliver.

WE MAY BE KNOWN FOR OUR TANKS. WHAT WE PROVIDE IS ENGINEERED PERFECTION.

Our holistic solutions are creative, considered and customised. Integrated, state-of-the-art and end-to-end to meet specific problems. Best of all – they work. We have thousands of customers, businesses, government departments and entire communities to back that statement.

Today, we continue to be proactive, investing time and energy into the role our technology will play in years to come. We're proud to be at the forefront of the industry, ahead of the curve and leading the way.

At Polymaster, together, we hold the future.

AUSTRALIAN STANDARDS

Polymaster is certified to ISO9001 International Standards and undertakes regular audits from third-party auditors.



Our tanks are certified to the Polyethylene tank standard for water & chemicals, AS/NZS 4766:2006 for 1SG, 1.5SG and 2SG. This means that every tank is independently tested & certified to SAI Global's AS/NZS 4766 standard and labelled to display manufacturing details and serial number for complete traceability.

About Product



Thank you for investing in a Polymaster underground tank.

Polymaster's underground rainwater storage tanks are the ideal product for collecting roof rainwater, filtering and storing it underground especially when space and accessibility are an issue.

This allows for more green space and/or parking on tight sites. The purpose of the underground rainwater tank system is to give home owners a complete package for saving the precious water that falls on the house and shed roofs which would usually be wasted.

With the smallest environmental footprint in the industry, Polymaster underground rainwater tanks give you the maximum capacity for the minimum square meterage.

Our underground poly rainwater tanks are the perfect addition to any property and can improve your home's water efficiency significantly. Manufactured to meet the highest standards, all of our approved and tested underground rainwater tank designs are made:

- To collect roof rainwater, filter it, then store it underground
- To run silently, out of sight, and with simple operation
- To withstand ground and water pressure at depth, as proven by stringent testing
- By geotechnical experts including finite element analysis (FEA)
- With an anti-flotation design and engineering specifications completed to AS1546
- With a sealed, locking tamper-proof lid
- Achieve a 6 star rating on new home builds

STRINGENT TESTING

Some of the stringent testing and standards we have complied to are listed below:

- Complies with AS4766 for the storage of potable water.
- Tanks have been designed using engineering design methods including finite element analysis (FEA) to withstand the worst-case soil condition load.
- Tested to AS1170.0-2002 (Structural Design Action, Part 0: general principals)

By following the installation requirements. You will find this tank will give you many years of trouble-free service.

WARRANTY

15- year design service life with a 10 year manufactures warranty
To validate your warranty, all installation instructions must be strictly adhered to and the Acknowledgement and release signed and returned to the Polymaster warranty department.

Refer to the end of this document for the warranty form.

Please note this warranty applies for the tank only. The submersible pump and automatic mains water changeover device are covered by the appropriate manufacturer's warranty.

Product Overview

URT3300

URT5000

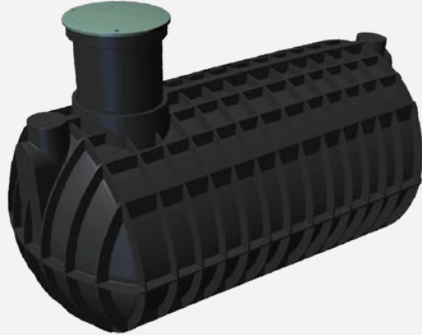

Spare Parts List

CODE	DETAILS
URRM	Riser underground tank
URLT	Lid only for underground TANK-HGR
M8X30SECSCR	Screw security M8 X 30 SS
URTSS	Screw driver - Security

Optional Extras

CODE	DETAILS
URVF01	Vortex self cleaning filter-200m

Optional Pump

CODE	DETAILS
HHR-370S-PC	Pump Hyjet 370w SUB/PC/CO SYSTEM
CHAINSTST	Chain 4mm SS

General Instructions



1.CONSTRUCTION SITE PRE-CHECK

The following points should be clarified before installation commences:

- The structural suitability of the ground (geotechnical report recommended)*
- Maximum groundwater levels which occur and drainage capability of the subsoil
- Types of load expected, for example: traffic loads
- Location of all underground services

* A geotechnical report conducted by civil testing engineers is strongly recommended to determine the physical characteristics of the subsoil before installation/ excavation commences. For setback distance from neighboring boundary and any buildings, please contact local council.

1.1 SAFETY

Substantial consideration and attention has gone into the design of this product. All precautions have been taken into account to ensure the purchaser's health and safety; however final health and safety resides with the persons installing the Underground tank.

Occupational Health and Safety legislation varies in each state, it is necessary to refer to the relevant regulations in your state at all times during Installation, servicing and repair.

1.2 INSTALLATION

The system must be installed by a qualified plumber/installer. Installation by a non-licensed person may void warranty. All wiring must be performed by a licensed electrician.

1.3 LIFTING OF TANKS

When lifting the tank into place use the appropriate lifting lugs provided on the tank and lower evenly into the excavation.

1.4 IDENTIFICATION OF WATER PIPES/ OUTLETS

All service water pipes and outlets leading from the Polymaster Underground tank should be identified in accordance with AS/NZS 3500.1: 2003 – section 9 and other relevant local plumbing regulations to avoid erroneous connection with drinking water supply.

To avoid the wrong connection with drinking water and rainwater all non-drinking tank outlets and rainwater pipework have to be marked clearly with "Rainwater" in accordance with local standards.

1.5 MAINTENANCE

In the event of work needing to be carried out inside the tank refer to applicable confined space state legislation.

Never leave tamper – resistant lid off a tank.

1.6 SITE

Refer to excavation and trenching legislation in your state about general excavation, Shoring, battering and depth-specific regulations. Ensure a safe site is maintained with appropriate safety signage and barriers to protect damage from third parties, during and after installation.

Note: It is the responsibility of the purchaser to ensure proper installation and maintenance of the underground tank. Polymaster will not be held responsible for any loss, injury or death resulting from a failure to observe all safety installation requirements and safe working procedures.

2. LOAD RATINGS FOR TANKS

2.1 PEDESTRIAN ACCESS

This tank has a load rated cover to 500kg. This makes it ideal for use in pedestrian traffic areas.

2.2 PASSENGER VEHICLES

Where the tank is in a zone where it could be susceptible to passenger vehicle traffic a removable cast iron lid (Class B) needs to be inserted over the standard tank cover. Minimum tank depths are displayed in the diagram for this application and groundwater must not be present. Maximum weight over this Polymaster tank is = 3.5 tonnes, gross vehicle mass (GVM)

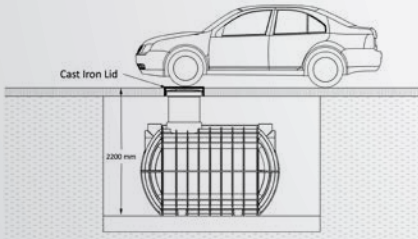

2.3 TRUCKS

Polymaster underground tanks must not be installed below areas used by vehicles heavier than passenger cars. For a class D loading contact Polymaster for specialist advice.

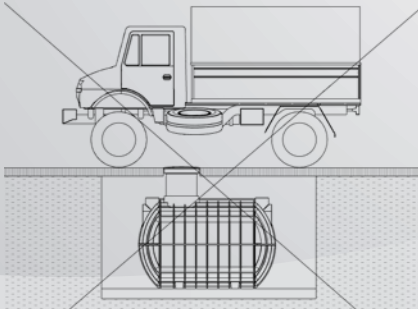

3. GROUND WATER

3.1 Careful consideration must be given in ascertaining the height of groundwater. Groundwater level must not be higher than the midline of the tank height.

The shaded area illustrates the allowable immersion depth for the tank. If the tank is in an area subject to vehicle traffic, there must be no groundwater present at all. If groundwater is higher than the midline contact Polymaster for further advice.

3.2 If groundwater is evident at the base of the hole after excavation place a PVC sleeve in one corner of the excavation big enough to fit a sump pump. (Leave the pump running inside PVC pipe and do not remove until backfill is up to the top of tank.) Once the tank is installed, backfill in 300mm layers and then remove pump and PVC pipe and fill the hole. Complete the installation.

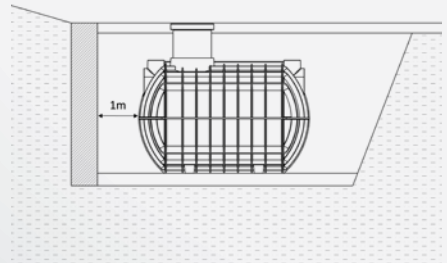

INSTALLATION AND ASSEMBLY

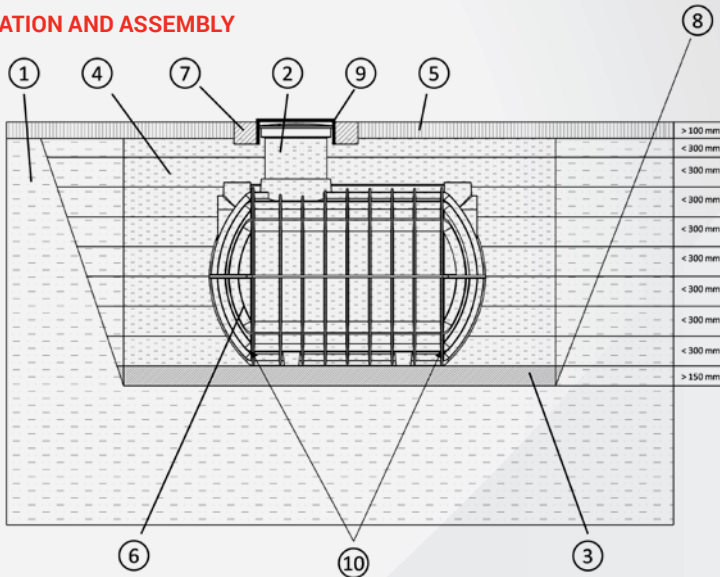

EXCAVATION AND MANUAL TAMPING/COMPACTION DETAILS:

- | | |
|---|--|
| 1. Natural earth | 6. Polymaster underground tank |
| 2. Riser | 7. Concrete slab for vehicular traffic surfaces (if req) |
| 3. Level compacted foundation– 20mm porous crushed rock | 8. Trench battering as per local regulations |
| 4. Backfill | 9. Cast iron lid if required |
| 5. Finished ground level | 10. Flat spots for connection to other tanks |

Note: Backfill hole must be compacted in 300mm layers

STEP 1. TRENCH EXCAVATION

Excavate hole according to dimensions of tank and in accordance with engineer report.

Ensure sufficient space, (not less than 300mm) is available for working around the tank during installation. Excavated soil must be kept well clear of the hole to prevent cave in.

Excavation slopes should be a minimum of 45 degrees.

The distance from solid constructions must comply with local regulations; refer to the current Building Code of Australia (BCA) – “angle of repose “. The trench embankment must be designed so that slippage or collapse of the embankment wall will not

occur. Hole depth should be 1660mm below finished pavement/lawn level if riser is not used. Allow depth of up to 2200mm if riser is used.

Remove all loose soil from base of hole and ensure base is firm, flat and level.

A level layer of mechanically compacted Type B crushed rock (depth approx. 100mm - 150mm) is applied as the foundation of the excavation. The depth of the trench must be calculated so that the maximum earth coverage above the tank is not exceeded.

If a vortex filter is being fitted before tank, this riser supplied is required.

STEP 1.1 INSTALLATION NEAR TO SURFACES SUBJECT TO HEAVY VEHICLE TRAFFIC

If the underground tanks are installed adjacent to surfaces which are used by vehicles heavier than passenger cars, the minimum distance (D1) away from these surfaces is at least the depth (D2) of the trench, which is 2200mm if riser is used.

Note: tanks must not be installed below areas used by vehicles heavier than passenger cars.

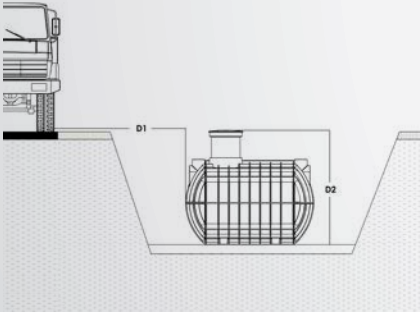

STEP 1.2 SLOPE, EMBANKMENT, ETC.

On installation of the tank in the immediate vicinity (<5 m) of a slope, a statically calculated (by an engineer) supporting wall must be erected to absorb the soil pressure. The wall must exceed the dimensions of the tank by at least 500 mm in all directions, and must be located at least 1m away from the tank.

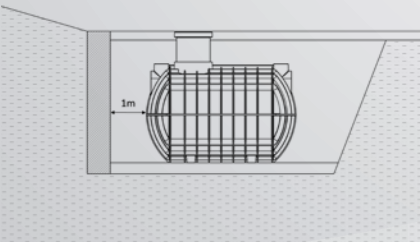

STEP 1.3 MULTI TANK CONNECTION

Tanks are connected via flat area at the base of the tank with 100mm DWV pipes through special Polymaster seals (supplied). A 127mm hole saw is required to fit the Polymaster seals.

A 25 mm irrigation pipe also needs to link tanks at the top to relieve air pressure whilst tanks are filling.

Ensure that the distance between the tanks is at least 300 mm.

The pipes must project at least 200 mm inside the tanks.

Note:

If installing multiple tanks together check inter connection joints and all rubber seals for damage and ensure they are installed correctly and all pipes are inserted the minimum 200mm before backfilling occurs.

STEP 2. PLACEMENT OF TANK

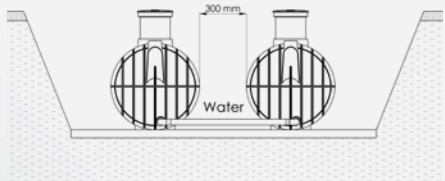

- Using the lifting points provided for stability, lift tank into place by use of a backhoe, excavator or crane
- The tank has four feet, ensure the tank does not sink into loose soil of hole, chock if necessary
- Using manhole for guide, level tank in both directions

The tank must be lowered impact free into the prepared trench excavation using suitable lifting equipment.

STEP 3. PLACING WATER IN TANK

When water table is below midline skirt of tank

- 3300Ltr tank – add 1000ltrs of water
- 5000Ltr tank – add 1500ltrs of water

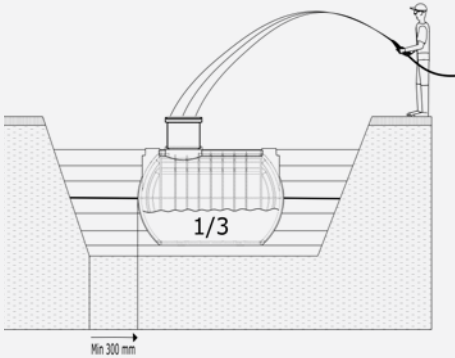

STEP 4. BACKFILLING

The surrounding area of the excavation is filled in layers (maximum 300mm steps) of appropriate 7mm minus or Type B crushed rock(Porous).

The individual layers must be well tamped/ compacted by hand held machine. Damage to the tank must be avoided

during tamping/compacting of backfill.

Note:

- Under no circumstances backfill the trench directly from the tip truck
- Ensure all tank opening are sealed before backfilling.

Backfill around the tank to pipe inlet depth

STEP 5. PLUMBING OF FEED AND OVERFLOW PIPES

All feed and overflow drain pipes must be laid on a grade of at least 1% in the direction of flow. Subsequent settling is possible and must be considered.

The tank overflow is connected to stormwater, it must be protected against reflux by using a suitable and accessible non-return valve and be in accordance with local regulations.

The Polymaster Underground Tank has a number of flat surfaces at both ends for feed and outlet pipes.

Use a 124mm hole saw to drill in the appropriate position. Refer to below the image.

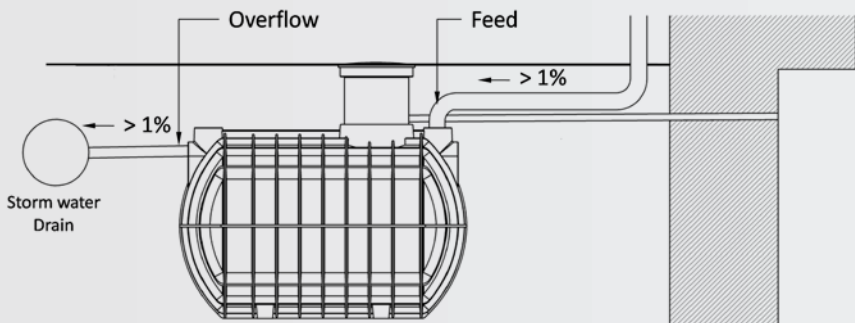

STEP 6. MOUNTING OF THE SELF-CLEANING VORTEX FILTER URVF01

- This filter can either be fitted in the ground alongside the tank or mounted to the wall of the house/ structure. A minimum one metre of horizontal stormwater pipe must be fitted before the filter.
- Before installing filter check whether a height difference between the rainwater outlet and the tank inlet has sufficient fall to keep stormwater pipe clear at all times. If this is cannot be achieved the filter is best to go on the wall of the adjoining house / structure near the downpipe. The URVF01 is suitable for 200sq metres of roof, for areas larger than this we recommend the larger capacity URVF15 model. This model requires a deeper installation
- After placing the Vortex filter in hole, make the pipe connections using 100, SWV pipe. The top half of the filter can rotate 360, this will enable easier connection to the inlet from the downpipe.
- In order for the Vortex filter to function properly, it must be installed exactly vertical.

STEP 7. PLUMBING UP SUBMERSIBLE PUMP

- Plumbing fittings have been supplied from pump to brass outlet fitted in tank. Fit these together and screw onto submersible pump.
- Mount lifting chain to pump by passing chain through eyebolt and lock with D shackle
- Fit poly pipe fittings to brass outlet in wall of tank.
- Mains water can now be plumbed into change over device or pressure switch and outlet pipes to laundry and toilets.

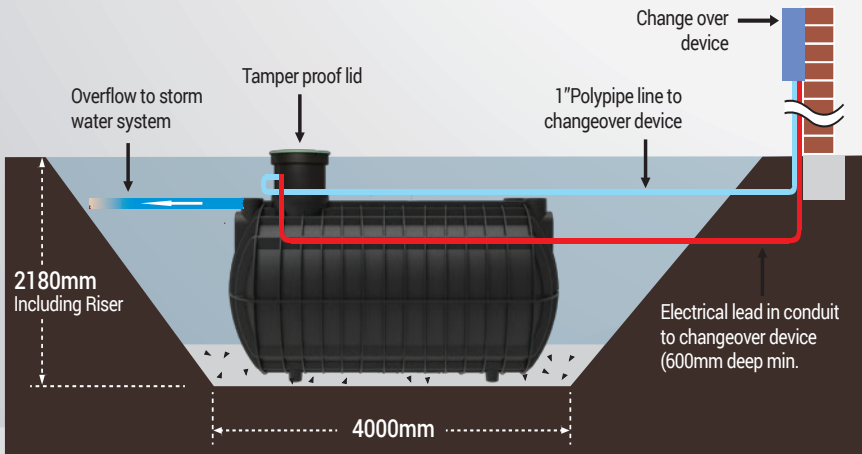

STEP 8. WIRING THE PUMP AND PRESSURE SWITCH

- The mains Water Changeover device (Controller) or pressure switch, can now be mounted outdoors or indoors onto a flat vertical surface.
- Cut off end of pump cable and pass through $\frac{3}{4}$ " plastic outlet in tank wall, into a conduit and then rewire pump cable into plug and controller.

NOTE: A licensed Electrician will be needed to carry out all electrical installations according to the relevant Australian Standards.

STEP 9. INSPECTION AND SERVICING

The entire system must be inspected for leaks, at the completion of the work. Settling of soil might occur and consideration needs to be given to allow for such.

Depending on local conditions the system may need to be serviced at regular intervals (every 12 months). In this case, all parts of the system should be cleaned thoroughly and their function checked. Servicing should be carried out as follows:

- Isolate water and power connections
- Drain the tank
- Clean surfaces and internal parts with clean water
- Remove any dirt/debris from the tank
- Check that all internal parts are properly positioned and firmly seated

In the event of work carried out inside the tank, as Occupational Health and Safety legislation differs from each state and territory, reference needs to be made to Occupational Health and Safety legislation pertaining to confined spaces.

Note: Please refer to safety notes and General safety instructions at the front of this installation manual

STEP 10. LANDSCAPING AND COMMISSIONING

Your tank is now ready to be fully covered in and paved or landscaped over. Tank lid is very strong and will be capable of withstanding 500kgs. A seal is provided under tank lid to prevent ingress of surface water

Data sheet

FUNCTIONAL DESCRIPTION

This is a rotationally moulded Polyethylene Underground storage tank.

Underground Tank

CODE	URT3300	URT5000
Manufacturer	Polymaster Pty Ltd	Polymaster Pty Ltd
Tank Type	Underground Tank	Underground Tank
Nominal Capacity (Ltrs)	3300	5000
Working Volume (Ltrs)		
Safe Fill Limit (Ltrs)	3135	4750
Tare Weight(Kg)		
MOC	Polyethylene-7032	Polyethylene-7032
Tank Dimensions (including Riser) - L x W x H (mm)	2469 x 1639 x 2173	3519 x 1639 x 2173
Manway Height (mm)	1666	1666
Max. Specific Gravity Rating	1	1
Colour	BLACK	BLACK
Standards Compliance	AS/NZS 1546.1:2008	AS/NZS 1546.1:2008

Standard Fitting Specifications

Riser	URT3300	URT5000
Diameter (mm)	Ø623	Ø623
Height (mm)	530	530
Colour	BLACK	BLACK
MOC	Polyethylene-7032	Polyethylene-7032
Inspection Hatch		
Size	140mm	140mm
MOC	Polyethylene-7032	Polyethylene-7032
Outlet		
Size	DN32	DN32
MOC	Brass	Brass

A POLYMASTER GROUP PUBLICATION

The information provided in this document is general in nature and does not take into account your personal situation. You should consider whether the information is appropriate to your needs, and where appropriate, seek professional advice. Although every effort has been made to verify the accuracy of the information contained in this document, Polymaster, its officers, employees and agents disclaim all liability (except for liability which by law cannot be excluded), for any error, inaccuracy in, or omission from the information contained in this document or any loss or damage suffered by any person directly or indirectly through relying on this information.

Optional Fitting Specifications

CODE	URT3300	URT5000
Pump- Option1		
Part Code	HSM-370PC	HSM-370PC
Make	HYJET	HYJET
Model	HSM-370PC	HSM-370PC
Voltage(V)	230	230
Power (HP)	0.5	0.5
IP Rating	IP55	IP55
Flow Rate(L/min)	82	82
Pump Body Casing	304 S/Steel	305 S/Steel
Controls		
Press control		
Make	HYJET	HYJET
Pump- Option2		
Part Code	HHR-370S-PC	HHR-370S-PC
Make	HYJET	HYJET
Model	HHR-370S-PC	HHR-370S-PC
Voltage(V)	230	230
Power (HP)	0.5	0.5
IP Rating	IP55	IP55
Flow Rate(L/min)	82	82
Pump Body Casing	304 S/Steel	305 S/Steel
Controls		
Change over device		
Make	HYJET	HYJET
Vortex Filter		
Part Code	URVF01	URVF01
Make	WISY	WISY
Model	WF 2002	WF 2002
Diameter(mm)	Ø315	Ø315
Height (mm)	483	483
Max. Water Flow (L/min)	4.2	4.2
Housing MOC	Polypropylene	Polypropylene
Colour	BLACK	BLACK
Filter (MOC)	S/Steel	S/Steel

LEGEND

- S/Steel – Stainless Steel
- MOC – Material of Construction
- Reference General Arrangement Drawings for further details of products

Warranty details

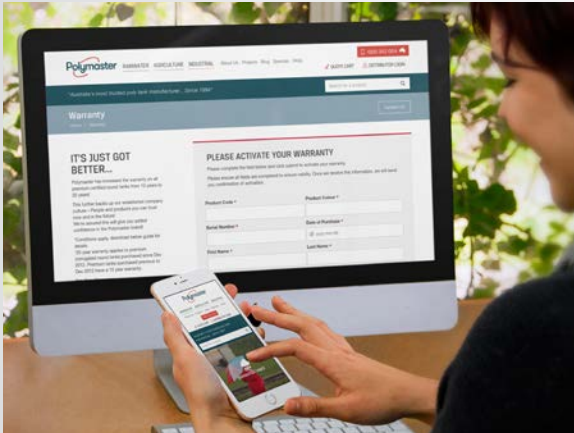

- Please activate your warranty online at warranty.polymaster.com.au

Alternatively, if you do not have access to the online warranty page, contact us on 1800 062 064

Polymaster underground tanks come with a ten-year manufacturer's warranty. It also meets with accreditation guidelines guaranteeing a service life of 15 years. To validate your warranty all installation instructions must be strictly adhered to. When you submit your warranty, you agree to adhere to the acknowledgement and release outlined below.

ACKNOWLEDGMENT AND RELEASE

The customer undertakes to install our underground tanks strictly to the manufacturer's directions, recommendations and specifications as contained in the Installation Manual accompanying the tank.

In the event of any loss or damage sustained or suffered by the Customer of whatsoever kind or wheresoever situated in the installation of these tanks, the customer agrees that he/she shall not hold the manufacturer (Polymaster) liable and acknowledges and accepts that the customer is wholly liable for such loss and damage and releases the manufacturer from any liability.

We would love to hear about your experience with Polymaster...

Please share your comments on our facebook page!

facebook.com/polymastergroupaust

Like us on  

Polymaster

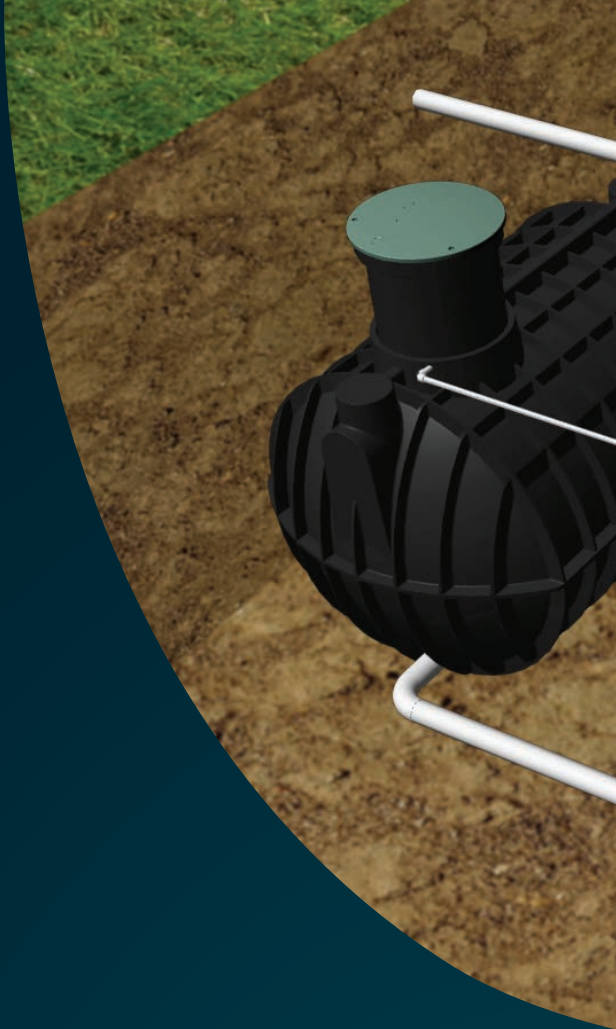

Together we
hold the future.

→ 1800 062 064
→ polymaster.com.au

Follow us  Polymaster Group